

SAVIOLI
METALMECCANICA



MADE IN ITALY

SINCE 1968

www.saviolimetalmecanica.it

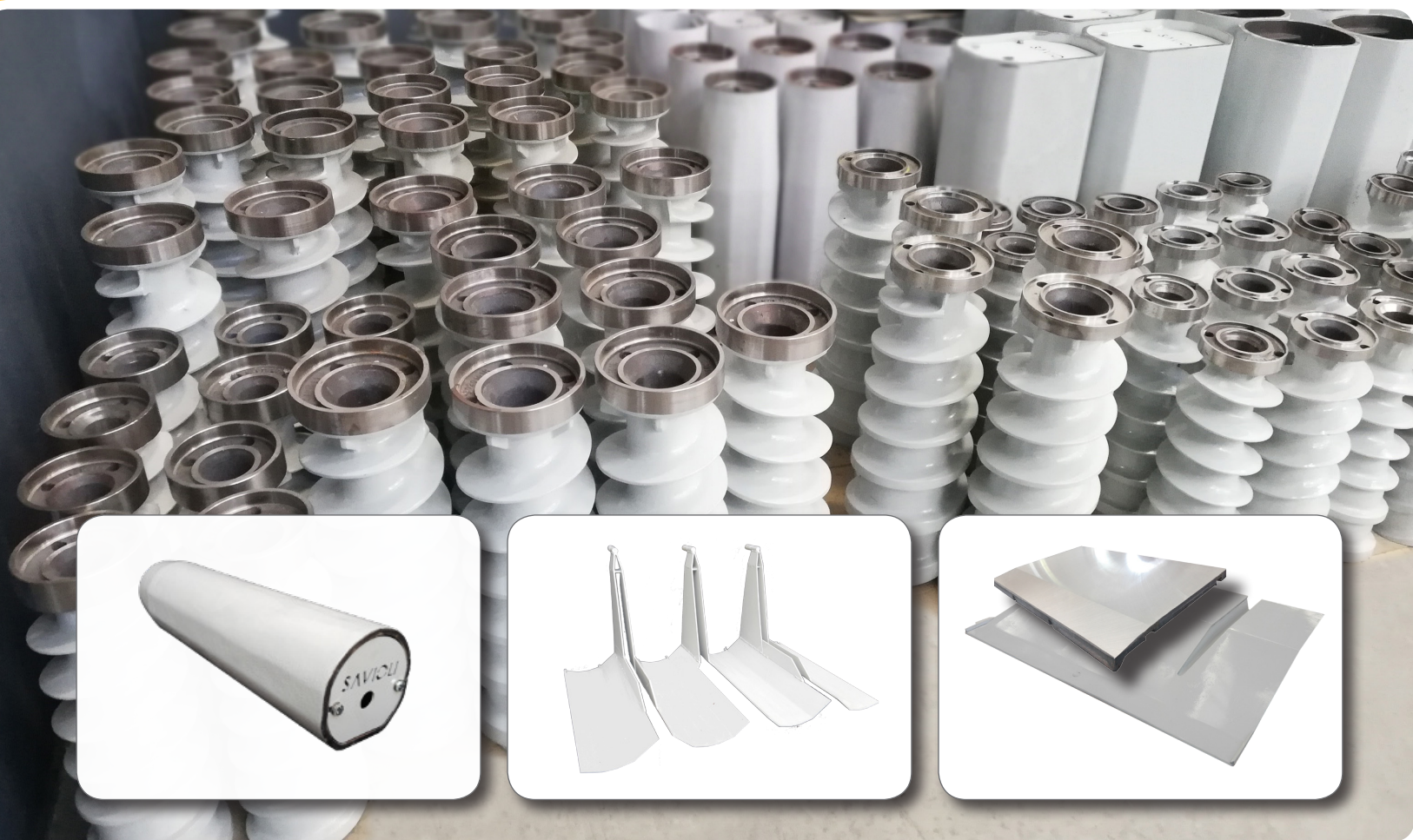

PRECAST TECHNOLOGY

**We produce all kinds of spare and wear parts for
concrete extruder machines.**

TECHNICAL SUPPORT • SALES • OVERHAUL • MAINTENANCE

SPECIALIZED IN HIGH QUALITY EXTRUDER SPARE PARTS AND PRECAST TECHNOLOGY

FLEXIBLE SOLUTIONS FOR ANY TYPE OF CONCRETE PLANTS



After twenty years' experience on all kinds of systems, we can perform maintenance and overhaul of nozzle module units, entire operating units, concrete mixing hoppers and slab saws.

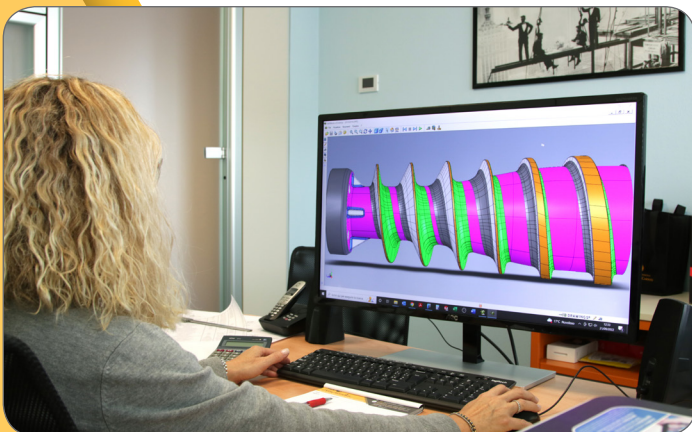

ENGINEERING DEPARTMENT

Availability and courtesy are the basis of our working relationship with customers. According to each single company's needs, our engineering department studies, designs and draws each part to meet even the smallest requirement. This department always works closely with production to find and meet any customer's requirements. This is why customer satisfaction is for us an added and essential requisite in our overall view of quality.



FACTORY AND WAREHOUSE

Spread over more than a 3700 m² indoor surface, our Company has a factory where all parts are built and repaired as well as a warehouse where we always have all parts in stock. Our flexible structure allows us to produce quantities smaller than the standard ones. This enable us to deal with orders accurately and quickly and thus reducing waiting times.

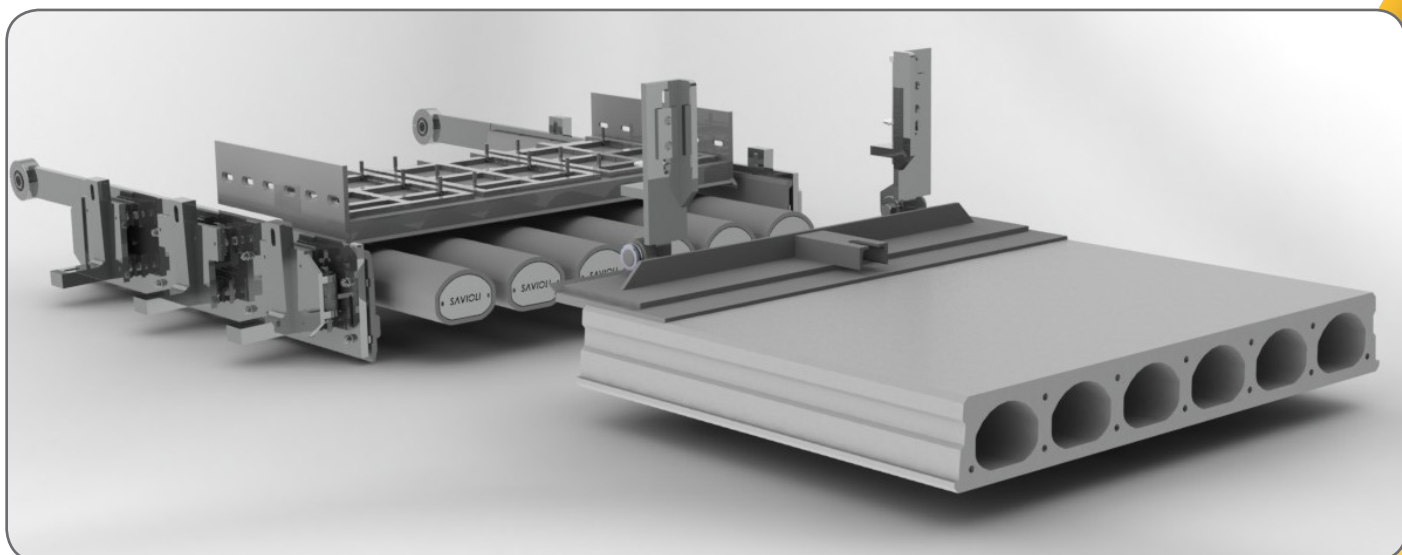
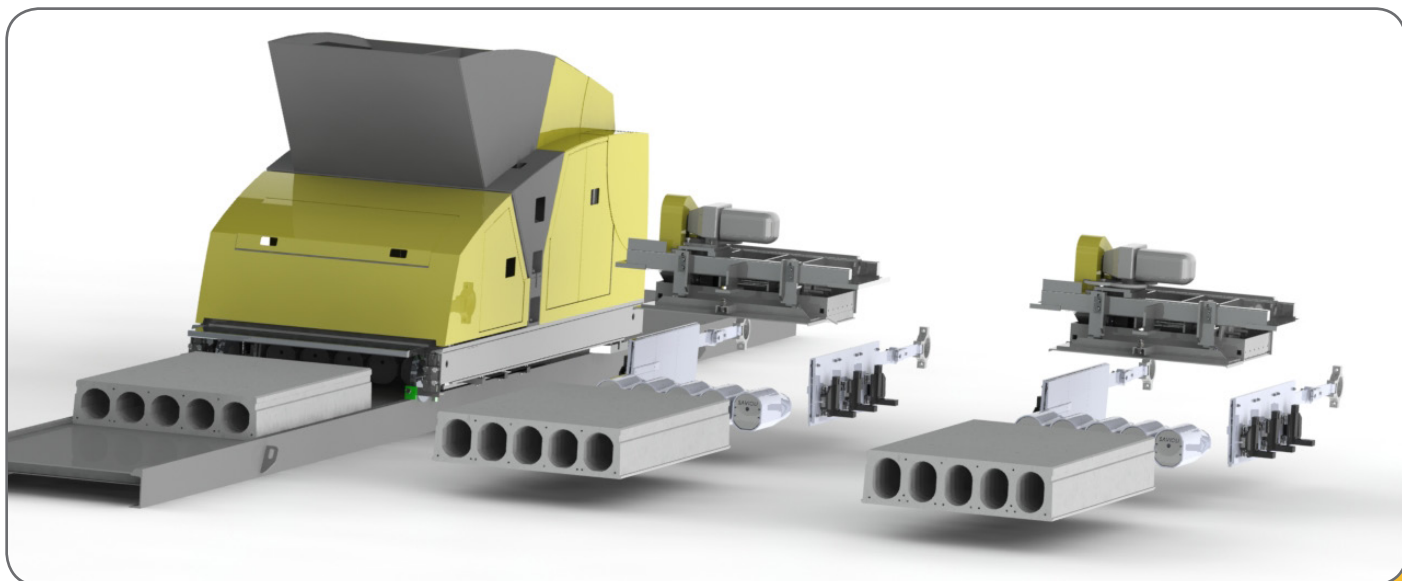
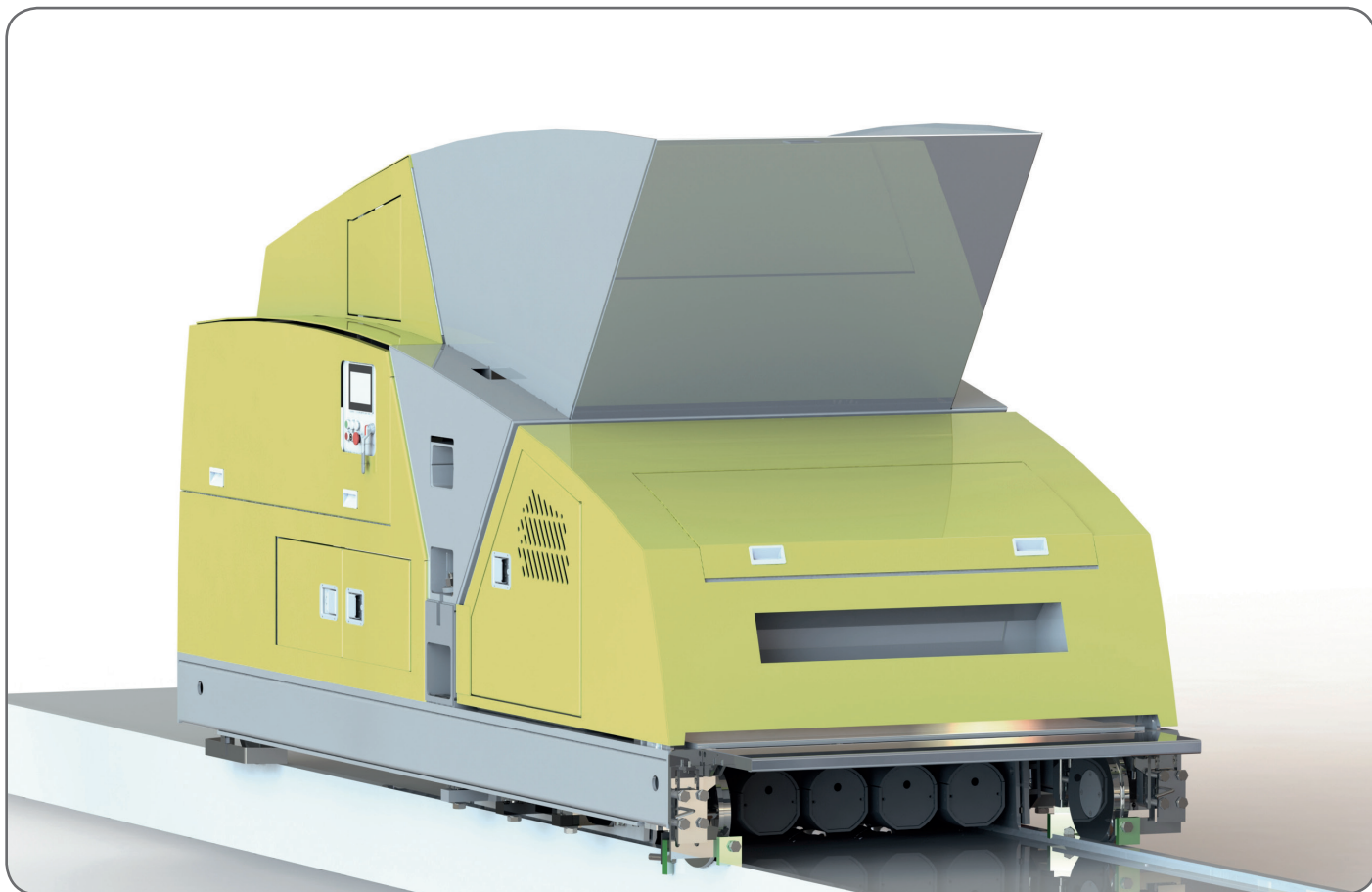



EXTRUSION **SCREW**



Centering ring integrated in screw casting

HOLLOW - CORE **SLEEVE**

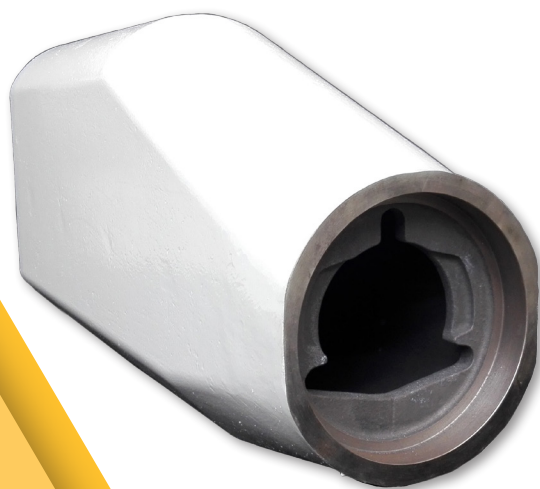

MASS **GUIDE**



SMOOTHING **PLATE**



EDGE **PART**



SMOOTHING **BEAM**

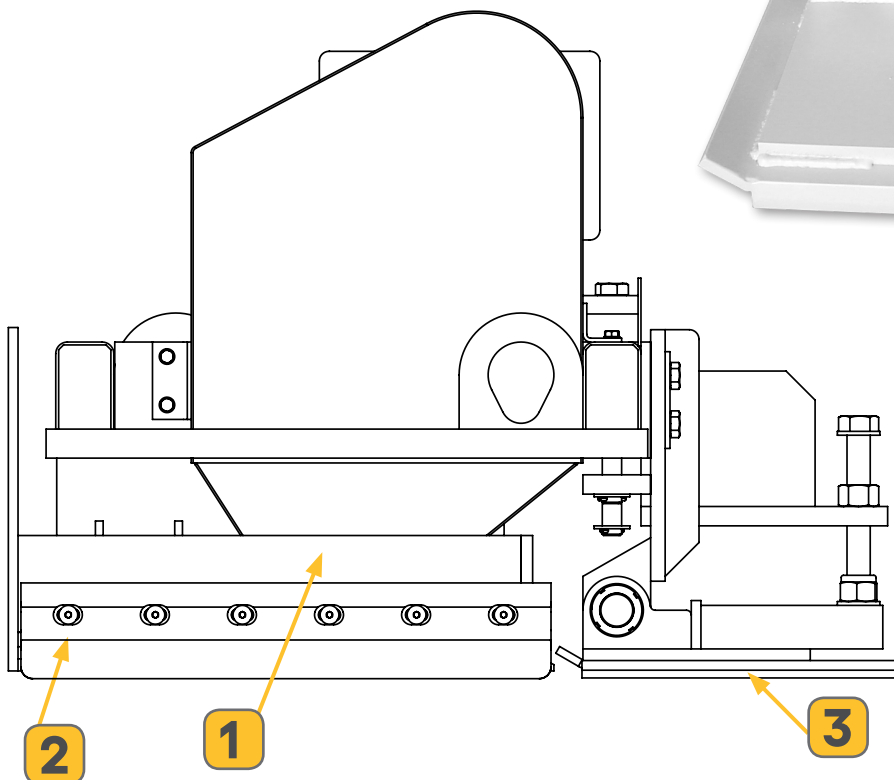
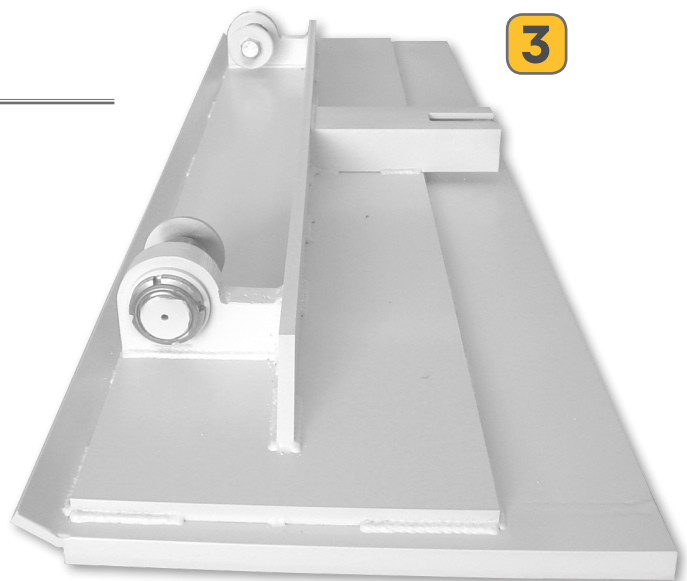



VOID 8



VOID 6



VOID 5



VOID 4

DAMPER **SIDE PLATE**



1



2

FLEXIBLE **SLEEVE**



3

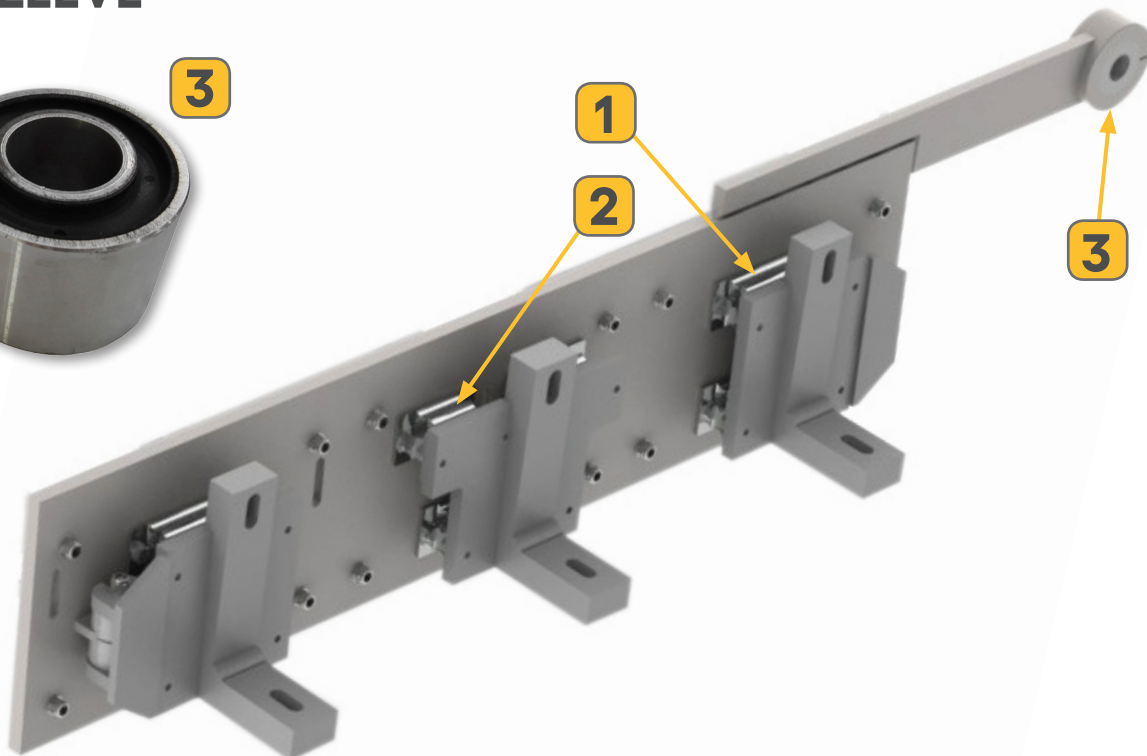

1

2

3

DAMPER **LEVELLING BEAM**

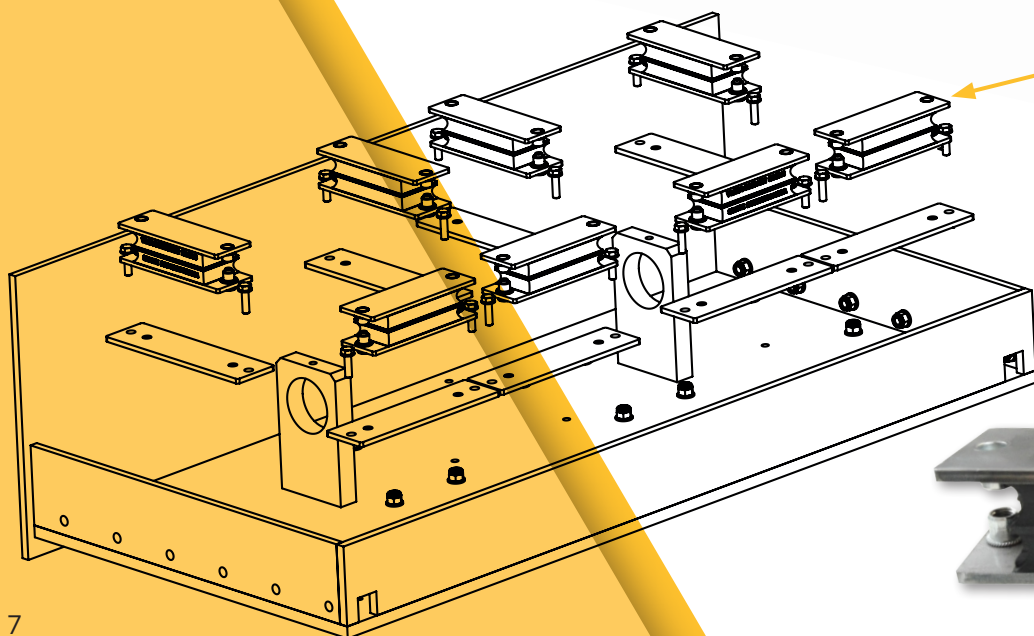

1

1



WEAR PLATE

GROUP: **MODULE** UNIT: **SIDE PLATE**

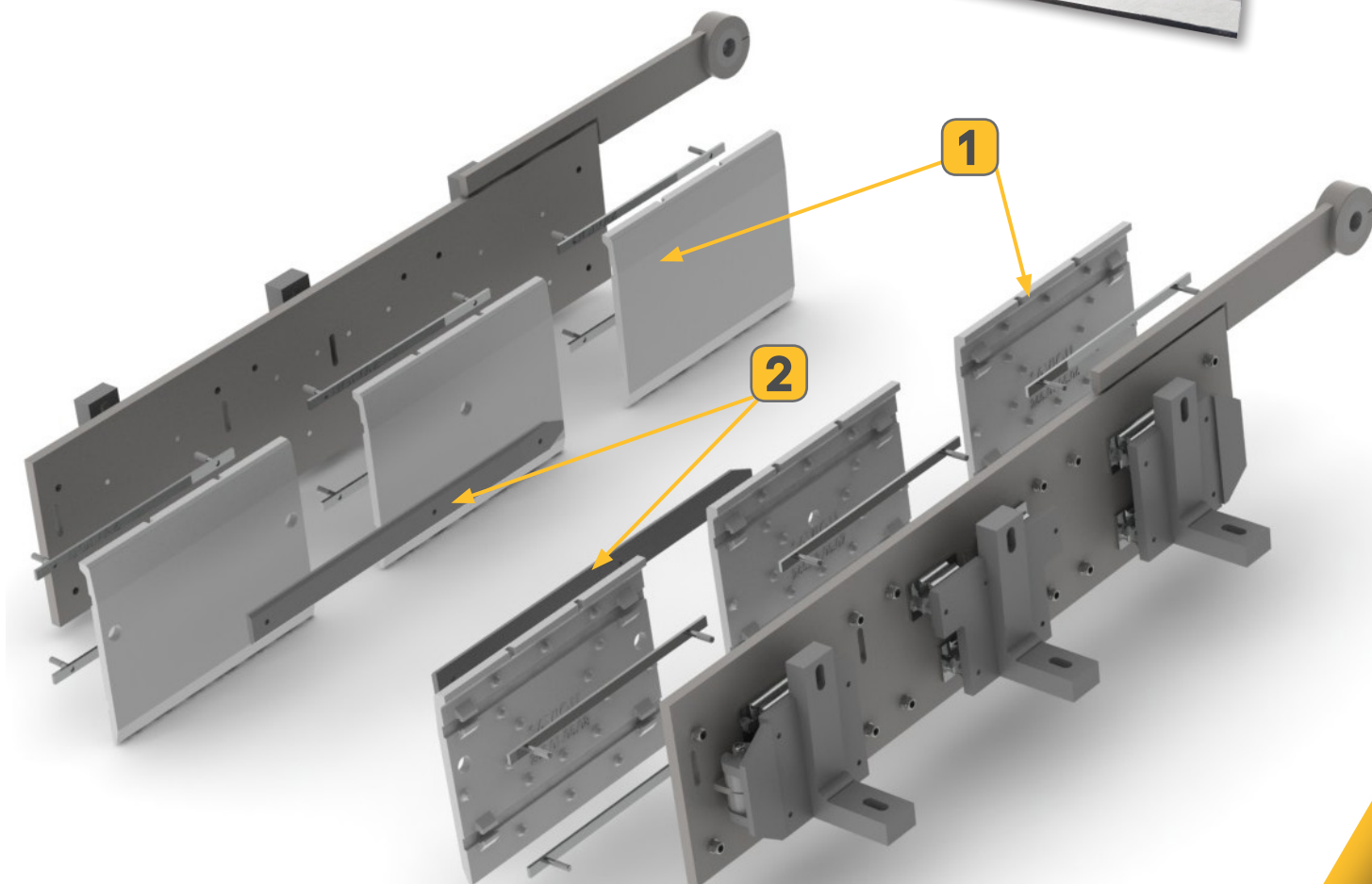

DOWEL BAR





STRAND GUIDE



SHAFT

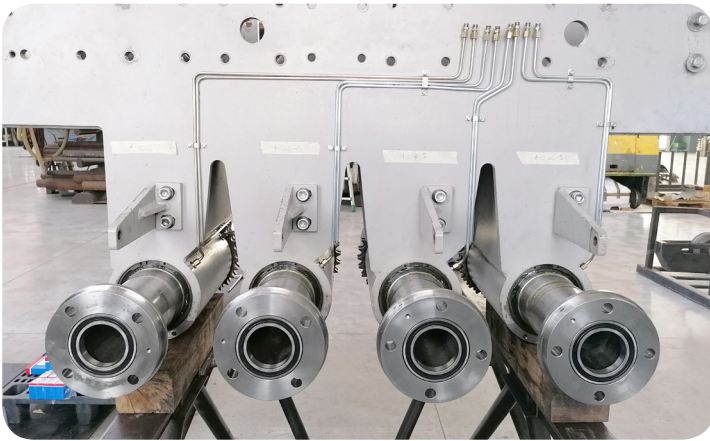

DRIVE SHAFT



FLANGE - MOUNTED BEARING



BEARING BUSHING



ECCENTRIC BUSHING



FASTENING FLANGE

CHAIN WHEEL

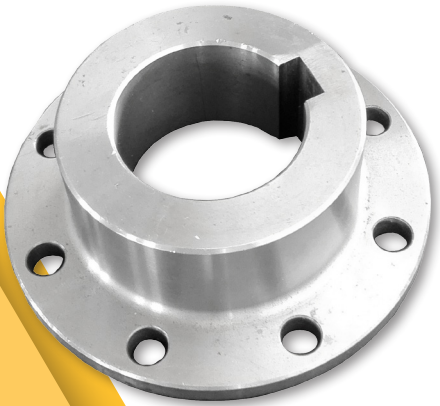

CONNECTING ROD

BUSHING





VOID 8



VOID 6



VOID 5



VOID 4

DRIVING BAR



SUPPORT ARM



CONNECTING ROD

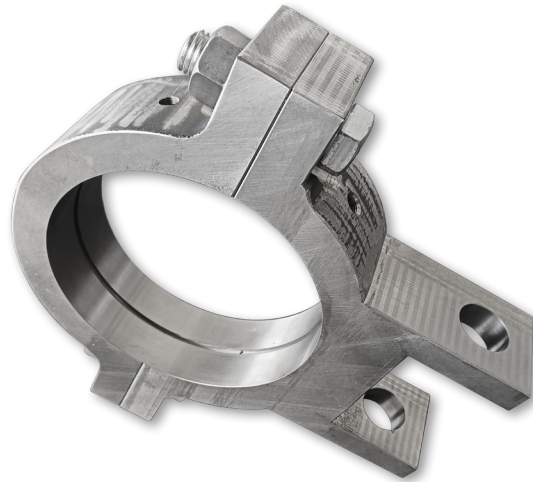

FASTENER



SINCE 1968



SAVIOLI
METALMECCANICA

37060 - Gazzo Veronese - Verona - Italy
Via Canove, 44 - Z. A. Roncanova

Tel. +39 0442 55 03 45

info@saviolimetalmecanica.it - www.saviolimetalmecanica.it